



FPC-8XX4X

OPERATION MANUAL

HydroSTART Pump Controllers

V1.6

MATElec Australia's HydroSTART Controller brings the features of the standard single and dual pump controllers into a new age with a redesigned capacitive touch keypad and control module with pump current sensing, providing wide range electronic overload protection which now functions with both single and three phase pumps. Additional control inputs and functionality has been incorporated into the new design to enhance the controller's flexibility and cover an even wider range of pumping applications. **The HydroSTART is the new standard for pump controls.**

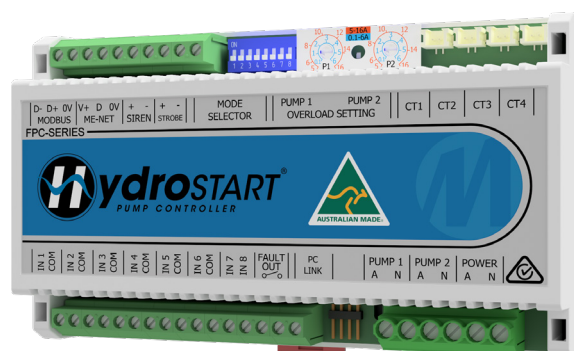



CONTENTS

3	HydroSTART Product Code Breakdown
3	Safety
4	Functions & Fault Protections
7	Installation
	Connections
7	Level Control Connections
8	Pressure Control, No Flow & Volt Free Connections
9	Power Supply & Pump Connections
10	Control Module - Features, Connections
	Current Sensing - Current Transformers, Current Sensing Range, Overload Protection, Undercurrent Protection, Zero Current Protection
11	
12	Thermal Overload Data - Thermal Overload Setup, Trip Curves, Cooldown
13	Soft Starter Data (ABB PSR) - Status Indication
14	DIP Switch Configuration
15	Keypad Operation - System Indicator Lights, Pump Indicator Lights, Level Indicator Lights, Buttons
18	Fault Diagnosis - Faults, Causes & Remedies, Other Common Issues
18	Maintenance
19	Optional Functionality
21	HydroSTART BMS Variation - VF Connections, Control Module Outputs
	HydroSTART RMC/PL Variation
22	Valve Installation, Rain/Mains Control Connections, Rain/Mains Keypad Operation
23	Rain/Mains Control Module Connections, Valve Fault Diagnosis
	HydroSTART RMC/AC Variation
24	Valve Installation, Rain/Mains Control Connections, Rain/Mains Keypad Operation
25	Rain/Mains Control Module Connections, Valve Fault Diagnosis
26	Conductivity Module

HydroSTART PRODUCT CODE BREAKDOWN

FPC-82143-E/BMS

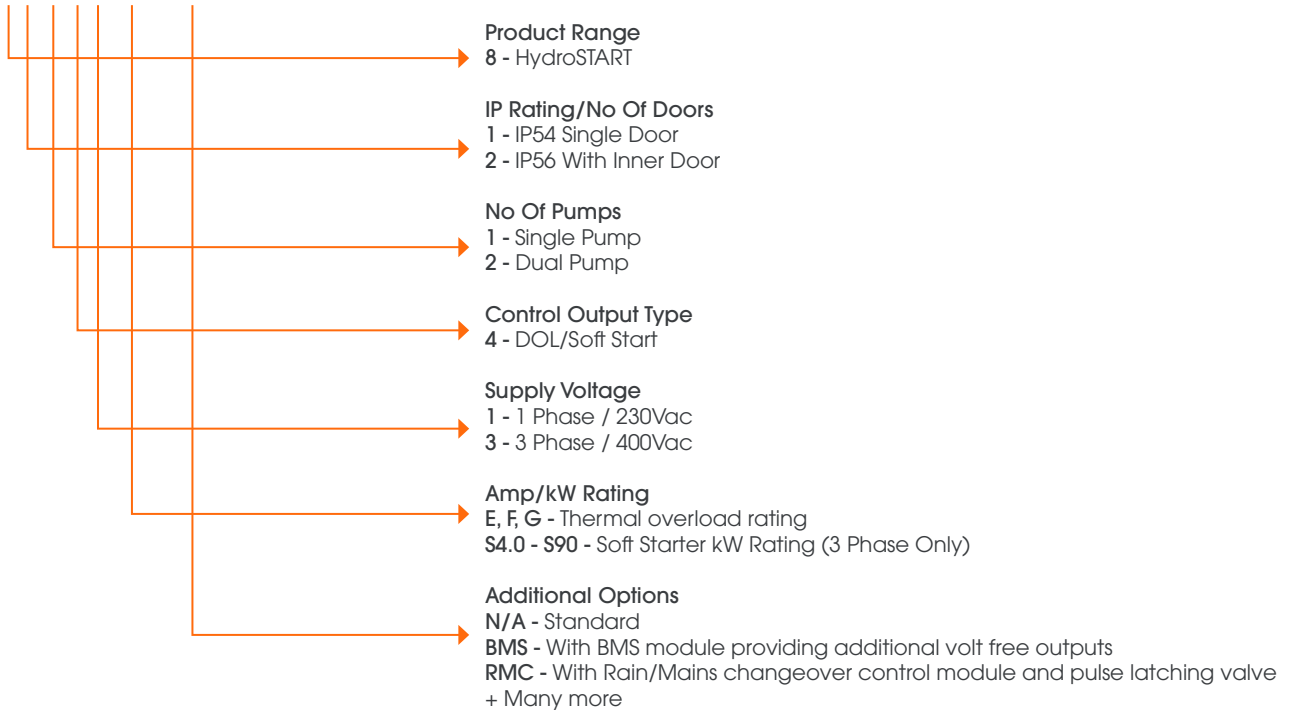

SAFETY

This control panel has been designed and built for applications that are Commercial and/or Industrial in nature, operation, function and location. If the control panel is to be used in Domestic/Residential applications, where specific Wiring Rules in respect of 'electrical supply' protection may apply, it is the responsibility of the installing electrician to ensure compliance with relevant standards.

- Prior to installation, ensure power supply is isolated.
- Power supply must be circuit breaker protected (qualified electrician to determine appropriate amp rating).
- Electrical connection to the panel must be carried out in accordance with the following pages.
- Additions or modifications to the control panel are not permitted and will void warranty.
- The controller is not intended for use by children or infirm persons without supervision.
- Repairs to the controller must only be carried out by a suitably qualified electrician.



This quick start guide makes use of the following symbols to indicate warnings that must be paid specific attention to:



Damage to equipment or personal harm may occur if this instruction is not followed



Electrical risk (electrocution hazard) may occur if this instruction is not followed

FUNCTION & FAULT PROTECTION

CONTROL MODES

The HydroSTART controller can operate in either Level or Pressure control mode. The control mode as well as many of the functions explained on the following pages are adjustable via the DIP switches on the control module. See 'DIP Switch Configuration' on page 14 for further information on the DIP switches. If DIP switch 1 is off, the controller will operate in Level mode, and if it is on, it will operate in Pressure mode. These selectable control modes make the HydroSTART controller suitable for various applications such as stormwater and sewage pump out, water transfer, pressure pumping and hot water circulation to name a few. The following pages explain the functions specific to each control mode.

DUTY SHARING & ALTERNATION

The HydroSTART controller features two modes for pump duty alternation. If DIP switch 3 is off, the controller will operate in standard alternation mode, in which the duty pump will alternate on every start and after 30 minutes of continuous running. This mode is suitable for most applications such as stormwater and sewage pump out. If DIP switch 3 is on, the controller will operate in recirculation alternation mode, in which the duty pump will alternate after 6 hours of accumulated run time. This mode is typically used in hot water circulation applications. In either mode, if the duty pump is shut down due to a fault, the controller will alternate to the other pump to keep the system operating.

LEVEL CONTROL MODE

If DIP switch 1 is off, the controller will operate in level control mode. Float switches are wired into the inputs as close on rise, and operation will be as follows. As the water level in the tank/pit rises and the duty start input closes, the duty pump will start, and will continue running until both the duty start and duty stop inputs open. If the water level continues rising and the standby start input closes, the standby pump will start to assist the duty pump and will stop when the standby start input opens. If the high level input closes, both pumps will start if not already running. After a high level event, and if the controller is in standard alternation mode (DIP switch 3 off), both pumps will continue running until the duty start input opens. In recirculation alternation mode (DIP switch 3 on), the standby pump will turn off once the standby start input opens.

HIGH LEVEL PROTECTION

The HydroSTART controller features two high level alarm modes. A high level alarm is indicated by a solid level alarm indicator light on the keypad, and will not shut down the pumps. If DIP switch 6 is off, the high level alarm will activate after the high level input is closed for 15 minutes and will automatically reset once the high level input opens. This mode is ideal for stormwater applications where large downpours may exceed the capacity of the tank/pit, allowing the system to resume normal operation once the level has subsided. If DIP switch 6 is on, the high level alarm will activate after the high level input is closed for 1 minute and will remain active until manually reset by pressing the mute/reset button on the keypad for 3 seconds. This mode is ideal for sewage applications to ensure the high level condition does not go unnoticed and any issues with the pumping system can be resolved.

MAXIMUM IDLE TIMER

In certain applications, it is desirable to keep the level in the tank as low as possible to prevent odour build-up or maximise overhead in the event of an inlet surge. The HydroSTART features a maximum idle timer, which will start a pump if either pump has not run for 4 hours and the pump stop input is closed. The pump will continue running until the pump stop input opens. This function is specific to the level control mode.

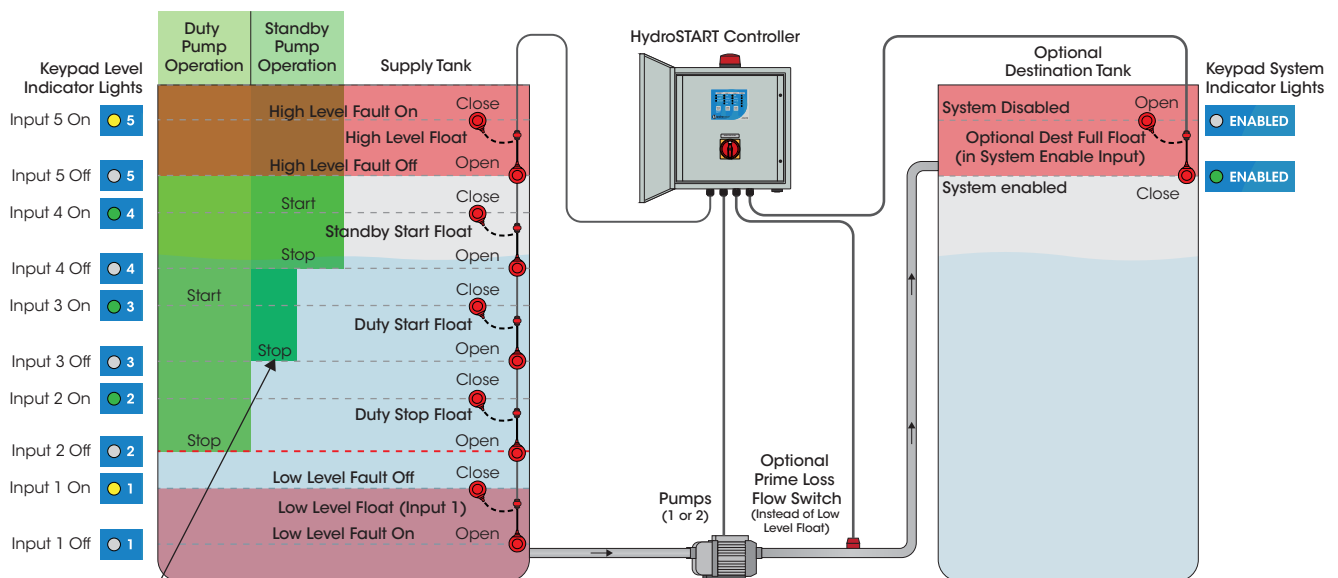

LOW LEVEL PROTECTION

If DIP switch 2 is on, input 1 will operate as a low level input. Low level protection will operate in both level and pressure control modes. If the low level input opens for 1 second, a low level fault will be activated and any running pumps shut down. The low level fault is indicated by the level alarm indicator light on the keypad flashing once. The fault will remain active until manually reset by pressing the mute/reset button on the keypad for 3 seconds. In level control mode, the low level fault will be overridden if the high level and one other float switch input closes, in which case the pumps will run. This functionality is designed to prevent the tank/pit overflowing in the case of a faulty low level float. If the high level input is closed, running both pumps, and then the low level and all other float inputs open, low level will override high and the pumps will stop. This is to prevent the pumps from running dry in the case of a faulty high level float.

PRIME LOSS PROTECTION

If DIP switch 2 is off, input 1 will operate as a no flow/prime loss input. Prime loss protection will operate in both level and pressure control modes. If the prime loss input opens for 30 seconds while a pump is running, a prime loss fault will be triggered and the pump shut down, with duty alternating to the other pump. If both pumps are running when the fault is triggered, both pumps will be shut down. A prime loss fault is indicated by the corresponding pump fault indicator light on the keypad flashing twice. The fault will remain active until manually reset by pressing the mute/reset button on the keypad for 3 seconds.

PRESSURE CONTROL MODE

If DIP switch 1 is on, the controller will operate in pressure control mode. Pressure switches are wired into the input as close on low pressure. If the system pressure drops and the duty start input closes for 1 second, the duty pump will start. The duty pump will remain running for 10 seconds even if the duty start input opens. These start and stop timers are designed to stop the pump 'chattering'. If the pressure continues dropping and the standby start input closes, the standby pump will start to assist the duty pump and will stop when the standby start input opens. If the low pressure input closes, both pumps will start if not already running. Both the standby start and low pressure inputs will only operate if the duty start inputs is closed.

LOW PRESSURE PROTECTION

If both pumps cannot build pressure and the low pressure input remains closed for 60 seconds, the low pressure fault will be activated and the pumps shut down. The low pressure fault is indicated by the level alarm indicator light on the keypad flashing twice. The fault will remain active until manually reset by pressing the mute/reset button on the keypad for 3 seconds.

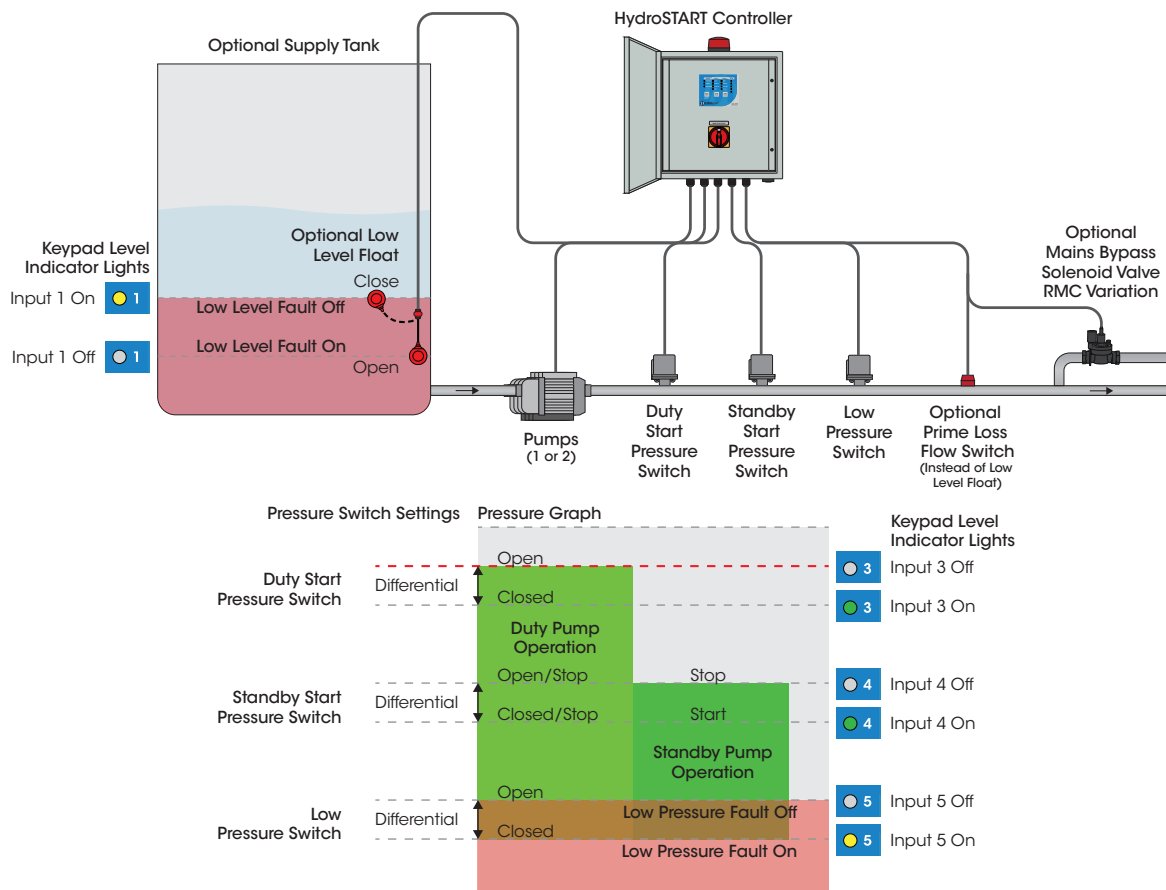

STAGGERED PUMP START

In some conditions, such as when power is restored after an outage, both pumps may be activated simultaneously. This causes undesired high current draw and associated voltage drop in the power supply cables. To prevent this, the HydroSTART controller features a staggered start delay of 3 seconds. If both pumps are to be started simultaneously, the controller will start one pump then wait 3 seconds before starting the other pump.

MANUAL PUMP CONTROL

Pumps can be run in manual mode via the pump mode button on the keypad. The corresponding pump's manual indicator light will illuminate when manual mode is selected. If DIP switch 5 is off, the pump will continue running in manual until the pump mode button is pressed again. If DIP switch 5 is on, the pump will revert to auto mode after 5 minutes of running in manual. Manual mode will not override fault lockouts but will override the system enable input.

SYSTEM ENABLE INPUT

In addition to the digital inputs used for pump control and level alarms, the HydroSTART controller features a system enable input which can be used to enable and disable the pumps in auto mode. A common use is in water transfer applications where a float switch in the destination tank is used to disable the pumps on high level to stop any more water being transferred. Other uses include enabling the controller from an irrigation system or BMS/SCADA system.

BMS & SCADA

The HydroSTART controller features a volt free output for common fault as standard. Further BMS outputs are available on the BMS variation of the HydroSTART range, which includes an additional BMS module, providing outputs for power on, low and high level, pump 1 run and fault, and pump 2 run and fault. For high level interface capability, the HydroSTART module features serial RS485 connections for communication to SCADA systems over Modbus RTU protocol, providing remote monitoring and control of the system.

ANTI-SEIZE PROTECTION

Anti-seize protection helps prevent pumps from seizing if the system sits idle for an extended period. The anti-seize timer will automatically run a pump for 5 seconds if it has not run for 7 days. Anti-seize will override all inputs including low level but will only run the pump if it is in auto mode and if not locked out due to a fault. The controller will alternate the pump duty so that the alternate pump is operated each time. Anti-seize protection will operate in both level and pressure control modes.

STATIC DUTY MODE

The HydroSTART controller features a static duty mode where the normal duty alternation is disabled. If DIP switch 8 is on, no pump duty or fault alternation will occur. Pump 1 will always operate as the duty pump, and pump 2 will always operate as the standby pump. This mode is ideal for applications where a smaller duty pump is used to handle lower flow rates or inflows, with a larger standby pump for periods of high demand.

PUMP CURRENT SENSING

The HydroSTART controller features current sensing, utilising current transformers mounted in the cable duct external to the control module. The current sensing provides overload protection for the pumps, with the amp range selectable via DIP switch 4 as low range (0.1-5A) or high range (5-16A). Two dials on the HydroSTART module are used for adjusting the trip threshold. The current sensing also provides undercurrent and zero current protections. These protections will trigger a pump fault with the corresponding pump fault indicator light on the keypad flashing. The undercurrent and zero current protections can be enabled or disabled via DIP switch 7. See '[Pump Current Sensing](#)' on page 11 for further information.

PUMP PROTECTION INPUTS

In addition to the pump protections provided by the inbuilt current sensing, the HydroSTART controller features a digital pump fault input for each pump. These inputs can be utilised for external thermal overloads, for controllers that require an overload amp rating above that provided by the inbuilt current sensing, as well as other inputs such as pump thermal switches. If a pump is running and its pump fault input opens for 1 second, a pump input fault will be activated, shutting the pump down.

SMART CHIRP MODE ALARMS

The HydroSTART features a smart 'chirp mode' audible alarm. If the audible alarm sounds continuously for 5 minutes without being muted, it will automatically silence and enter 'chirp mode', sounding briefly for 2 seconds every 5 minutes.

The HydroSTART also features some other functions which are not included as standard but can be enabled upon request, including tank fill control mode and pump max run protection. See '[Optional Functionality](#)' on page 19 for further information.

INSTALLATION

- Controller enclosure must be mounted in a vertical position.
- Ensure mounting method does not compromise enclosure weatherproof rating.
- IP54 single door controllers are only suitable for mounting indoors, while IP56 controllers with inner door can be mounted outside.
- Ensure access to main isolator is not restricted.
- Ensure cables/conduits entering the panel have mechanical protection and that the penetrations are sealed and do not compromise the weatherproof rating of the enclosure.
- If required, install buzzer through hole on underside of enclosure and tighten lock ring.

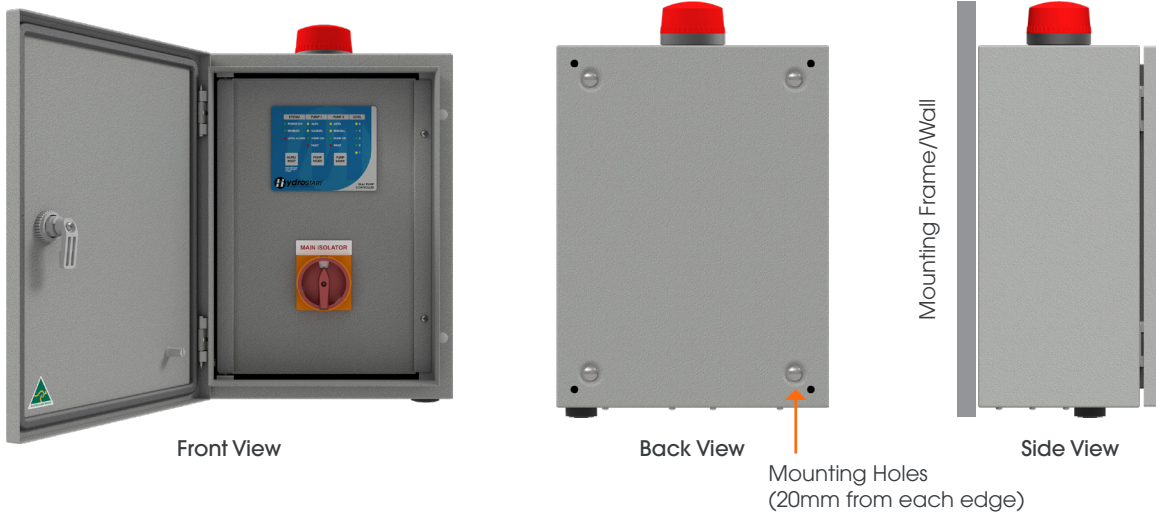

CONNECTIONS

Warning: All electrical connections must be carried out by a suitably qualified and registered electrician

Level Control Connections - Single Pump

C	C	C	C	C
Input 1	Input 2	Input 3	Input 5	System Enable
Low Level	Duty Stop	Duty Start	Alarm Level	
INPUT				
12Vdc				

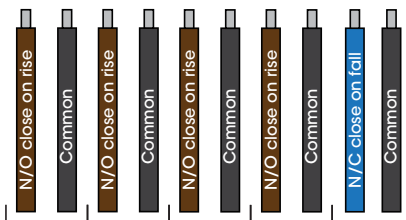

Bridge if not required	Leave open if not required	Bridge if not required
------------------------	----------------------------	------------------------

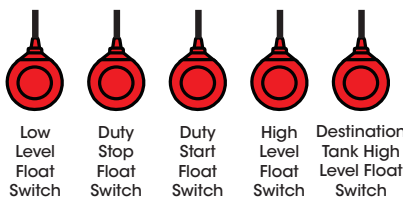

Level Control Connections - Dual Pump

C	C	C	C	C	C
Input 1	Input 2	Input 3	Input 4	Input 5	System Enable
Low Level	Duty Stop	Duty Start	Standby Start	Alarm Level	
INPUT					
12Vdc					

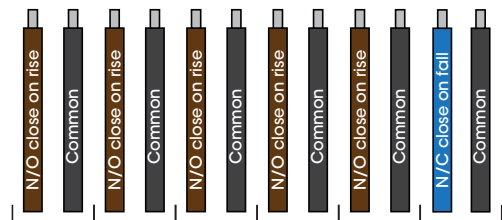

Bridge if not required	Leave open if not required	Bridge if not required
------------------------	----------------------------	------------------------

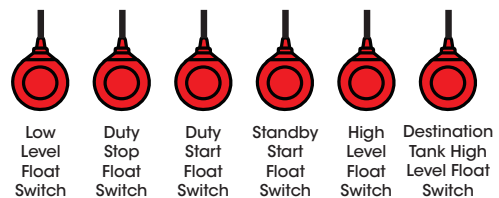

Pressure Control Connections - Single Pump

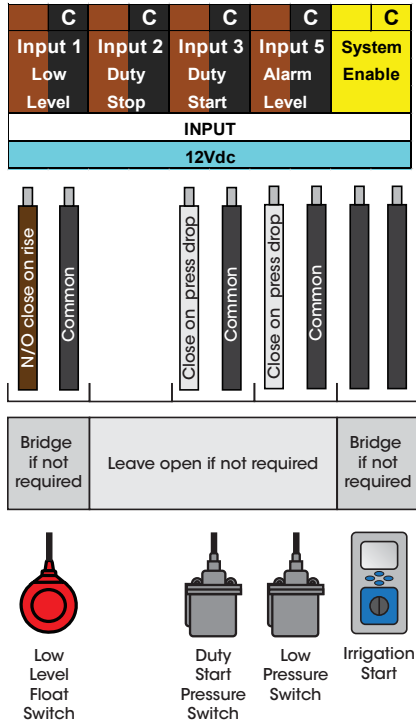

Pressure Control Connections - Dual Pump

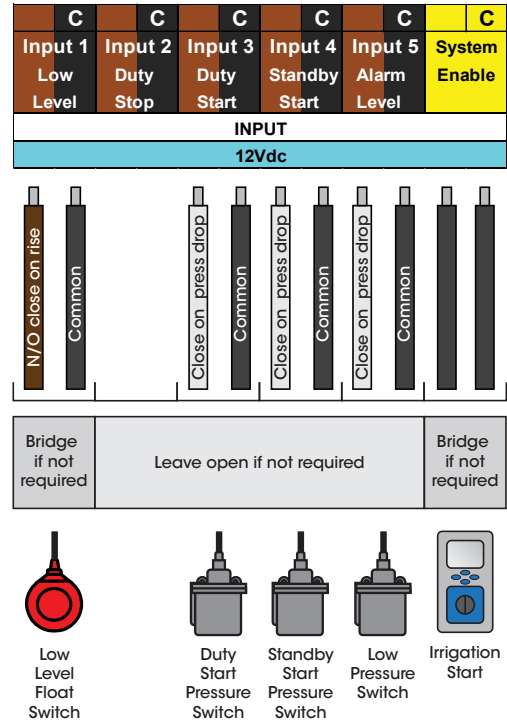

Prime Loss Connection

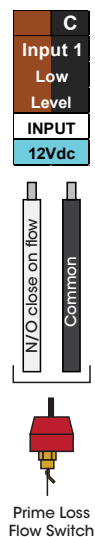

VF Connections

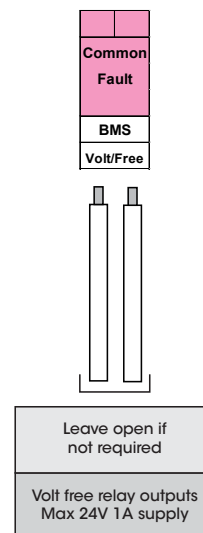

Note:

- The above shows the full range of connections available. Not all connections are necessary for operation.
- Modbus RTU Serial RS485 connections for SCADA are also available on the HydroSTART control module. Din rail terminals are not provided as standard for these connections, but they can be wired directly to the module. See 'Control Module' on page 10 for further information.

POWER SUPPLY & PUMP CONNECTIONS

Single Pump, Single Phase

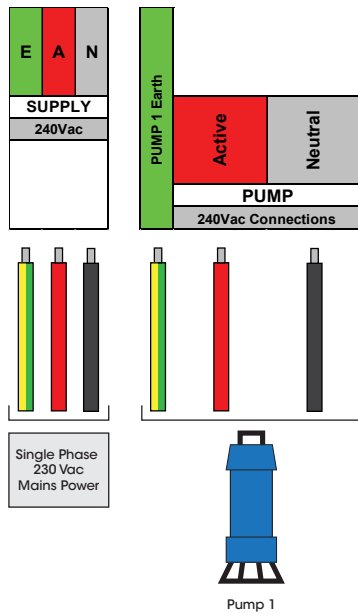

Single Pump, Three Phase

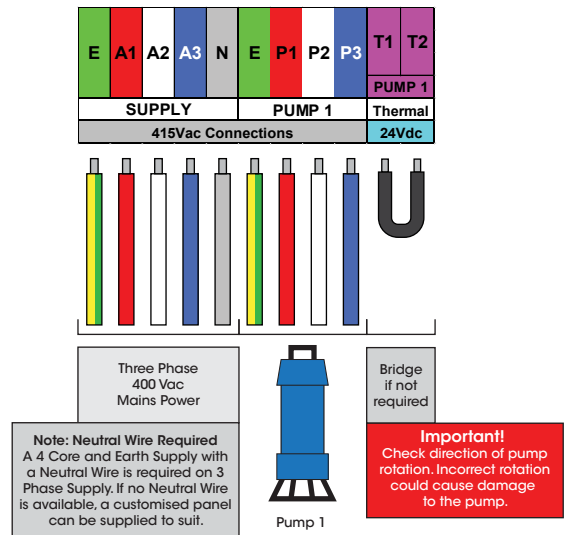

Dual Pump, Single Phase

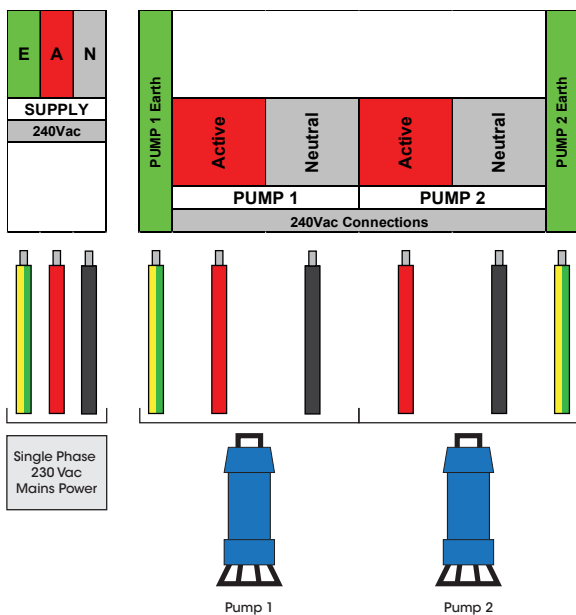

Dual Pump, Three Phase

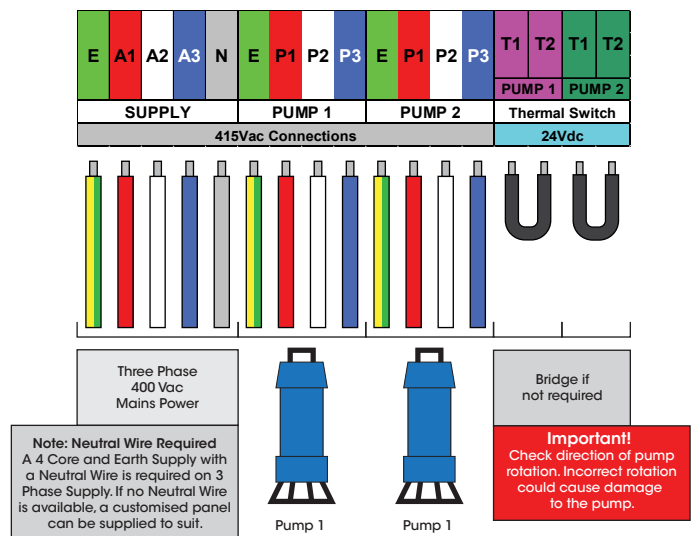

CONTROL MODULE

FEATURES

- Single module is used for single and three phase, single and dual pump controllers.
- 240Vac power supply with 240Vac to 12Vdc convertor, overload protected.
- 8x Digital inputs for pump control and alarms, system enable and pump faults.
- 1x Volt free auxiliary output for common fault signal.
- 2x 240Vac full load switched outputs for pumps 1 and 2. These can handle full pump current up to 16 Amps for single phase pumps, or are used to switch contactors for three phase pumps.
- 4x Current transformer connections for CTs mounted external to the control module.
- 2x Alarm outputs for siren and strobe, overload protected.
- RS-485 connections for SCADA connection over Modbus RTU, providing access to status information and parameters.
- ME-NET connections for communication to HydroSTART keypad, BMS module and BMS/Conductivity module.
- 8x DIP switches for adjusting control mode and various other functions.
- 2x overload dials for adjusting pump 1 and 2 overload trip current.

CONNECTIONS

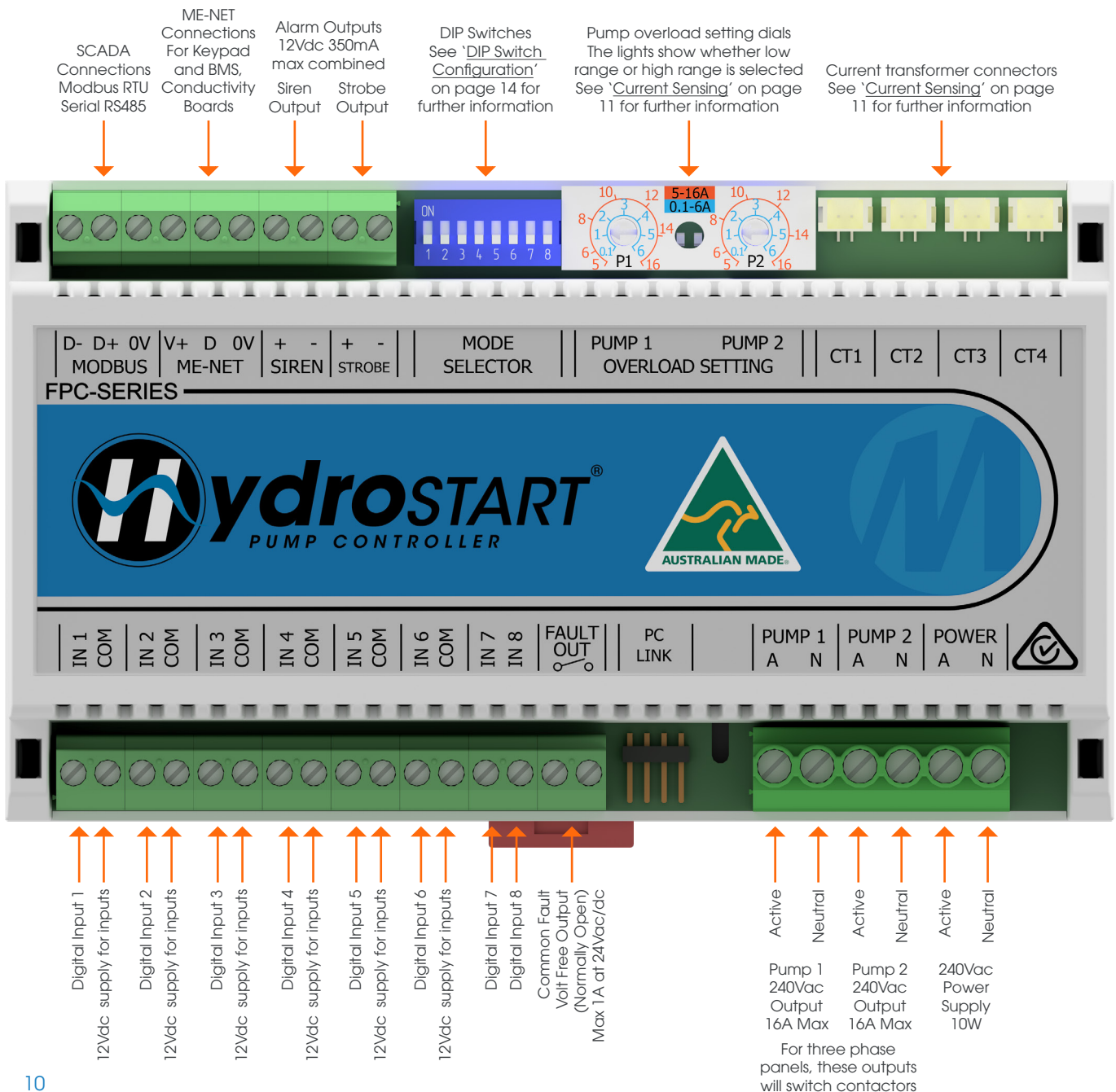

PUMP CURRENT SENSING

CURRENT TRANSFORMERS

Pump current sensing in the HydroSTART controllers is provided using externally mounted current transformers. These are typically mounted within the cable duct above the pump circuit breakers. The CTs feature two wires in a twisted pair with an outer insulative layer. The CTs are connected to the CT connectors on the upper side of the HydroSTART control module. In single phase controllers, one CT per pump will be used. In three phase panels, two CTs per pump will be used, monitoring two of the three phases. The order of the CT connections is not important, as the HydroSTART's control algorithm will automatically determine which CTs are being used for each pump when the controller is powered up.

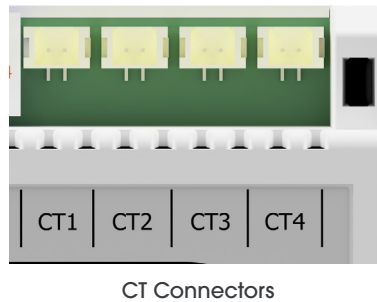
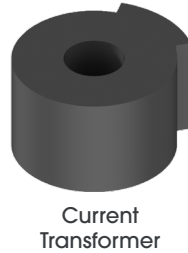

CURRENT SENSING RANGE

The HydroSTART can operate in two current sensing modes: Low range (0.1 - 6 Amp) or high range (5 - 16 Amp). The current sensing mode is selected via DIP switch 4. DIP switch 4 off = low current range, DIP switch 4 on = high current range. The current sensing range in use is also indicated by the LEDs located in between the pump overload setting dials. If the LEDs are blue, low current range is selected, and if they are orange, high current range is selected. The current sensing range is set to the Low range (0.1-6amp) as factory default. The user must check the range and overload setting is correct for the motor size connected before operation. For pumps with full load currents above 16 amps, the HydroSTART's current sensing cannot be used and external thermal overloads are required, see 'Thermal Overload Data' on page 12 for further information.

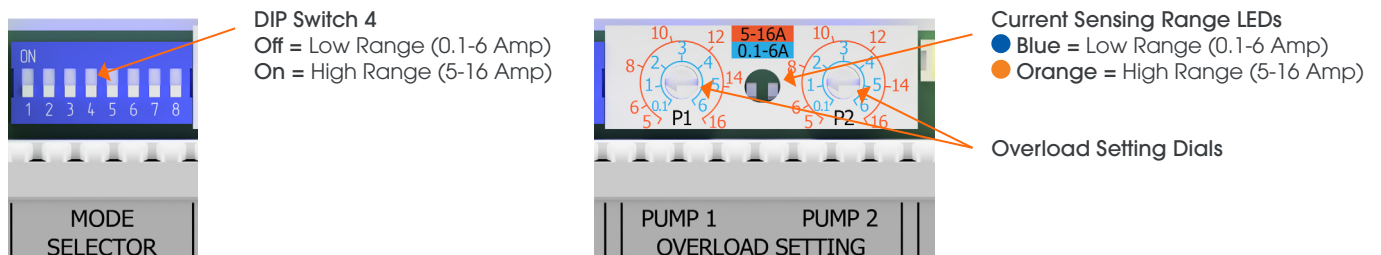

OVERLOAD PROTECTION

The HydroSTART's overload protection utilises a modified D trip curve overload function on each monitored phase. The overload trip threshold is selected via the overload setting dials shown in the image above. The threshold set by the dial corresponds with either the blue or orange scale, depending on which current sensing range is selected. The overload trip threshold should be set according to the full load current (FLC) shown on the pump nameplate. If either phase triggers an overload trip a pump fault will be activated, indicated by a solid pump fault indicator light on the keypad, and the pump shut down. The fault will remain active until manually reset by pressing the mute/reset button on the keypad for 3 seconds.

UNDERCURRENT PROTECTION

Undercurrent protection can be enabled or disabled via DIP switch 7. If a pump is running and the current being sensed on each monitored phase is below 50% of the setting on the overload dial for 10 seconds (but above 100mA or 10% of the value set on the overload dial, whichever is higher), an undercurrent fault will be activated, indicated by the corresponding pump fault indicator light flashing 5 times, and the pump shut down. The fault will remain active until manually reset by pressing the mute/reset button on the keypad for 3 seconds.

ZERO CURRENT PROTECTION

Zero protection can be enabled or disabled via DIP switch 7. If a pump is running and the current being sensed on each monitored phase is below 100mA or 10% of the setting on the overload dial for 10 seconds (whichever is higher), a zero current fault will be activated, indicated by the corresponding pump fault indicator light flashing 4 times, and the pump shut down. The fault will remain active until manually reset by pressing the mute/reset button on the keypad for 3 seconds.

THERMAL OVERLOAD DATA

Note - This section is only applicable to HydroSTART controllers with external thermal overloads installed, and the current sensing is not in use. External overloads are used when the pump full load current is above 16 amps and/or soft starters are in use.

THERMAL OVERLOAD SETUP

The full load current (FLC) is written on the name plate of the pump and is required to be set on the thermal overload for the pump or motor's protection. If this value is set too high, there is potential that the pump may be damaged. If set too low the pump will go into fault prematurely during normal operation. Ensure power is isolated before opening the enclosure to set the thermal overloads. The auto reset button should be left in auto (screwed down) so that the controller can latch and reset the faults from the keypad without the need to access the live parts.



THREE PHASE	
CAT.NO.	JM3550
SPEC.	35F84W7
FRAME	56J SER. F1295
H.P.	1 1/2T E
VOLTS	208-230/460
AMPS	7.6/2.3
HZ	50

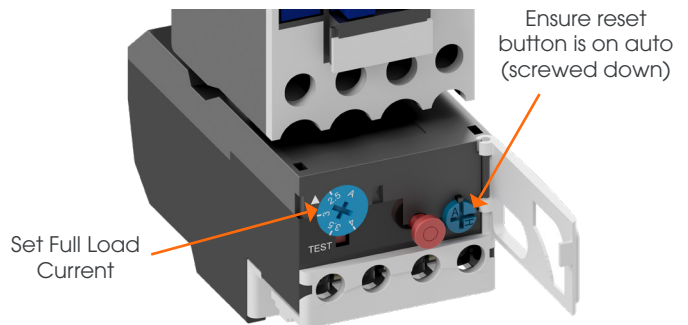

The thermal overload is designed to open the starting circuit and thus cut the power to the motor in the event of the motor drawing too much current from the supply for an extended time. The overload relay has a normally closed contact which opens due to heat generated by excessive current flowing through the circuit. To test the thermal overload is working correctly put a pump into manual run and while running hold in the test button with a small screw driver for 5-10 seconds. This should simulate excessive current and activate a pump fault.

TRIP CURVES

The current sensing circuits can measure a maximum of 11x the full load current. The trip time will vary based on the temperature of the overload, as can be seen in the adjacent graph. If cold, the fastest trip time is approximately 2.5 seconds and once warmed up the fastest time is reduced to approximately 800ms. Key times to trip are:

MULTIPLE OF OVERLOAD SETTING FOR 3PH AND HEAT STATUS	TRIP TIME
1x	Will not trip
1.05x	Approx 8 minutes
1.5x	Approx 1 minute
5x	Approx 2.3 seconds
10x	Approx 800 milliseconds

As for thermal relay specific time-current characteristic curve, please see the graph to the right.

COOLDOWN

By nature of their construction, bimetallic strip based overloads have an automatic cooldown time after a trip event before the overload can be reset. When an overload condition results in the unit switching off the pump the cooldown will begin. The time for bimetallic strip cooldown is affected by the surrounding ambient temperature and the multiple of rectified current. During the cooldown period it will not be possible to reset the overload fault for that pump. Typically there will have been a sufficient period of time between the fault being triggered and a technician arriving on site for the cooldown time to have elapsed anyway.

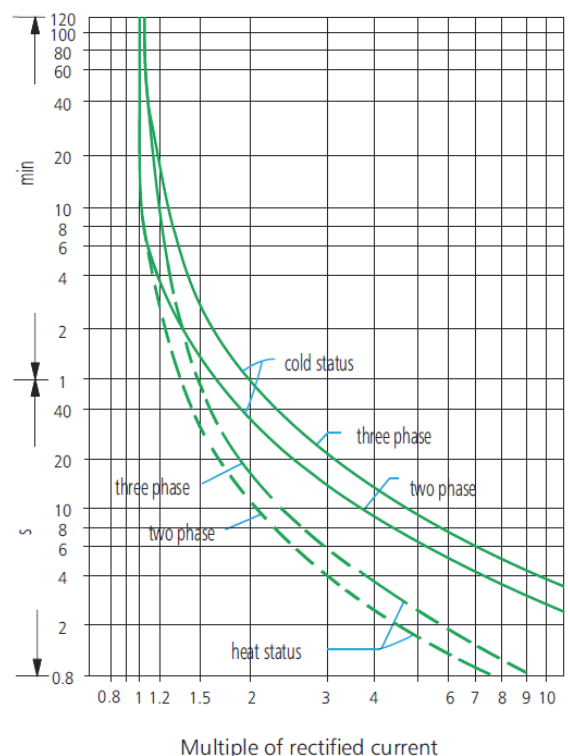

SOFT STARTER DATA (ABB PSR)

Note - This section is only applicable to HydroSTART controllers with soft starters installed. Soft starters are recommended when the pump full load current is above 18 amps. HydroSTART controllers with soft starters typically use the ABB PSR models.

The soft starter is rated for 10 starts per hour with 6s acceleration time, 4x FLC at 40°C. Care must be taken to limit pump starts to within the manufacturer's specification. Going beyond these limits will reduce the acceptable number of starts per hour.

- **Setting the Start Ramp Time** - Set the acceleration ramp time for the motor to reach full speed. Exceeding 6 seconds will reduce the acceptable number of starts per hour.
- **Setting the Stop Ramp Time** - If required, adjust deceleration to reduce water hammer. This will reduce the acceptable number of starts per hour.
- **Setting the Initial Voltage** - For high starting current motors, set the initial voltage high enough to get motor rotation started.

STATUS INDICATION

On/Ready indicator light:

- Flashing - Soft Starter control circuit is powered (A1 & A2)
- Steady - Soft Starter has mains voltage (L1, L2 & L3) and is ready to run

Run/TOR indicator light:

- Flashing - Soft Starter is ramping the voltage to the pump up or down
- Steady - Soft Starter is at top of ramp, running the pump at full voltage

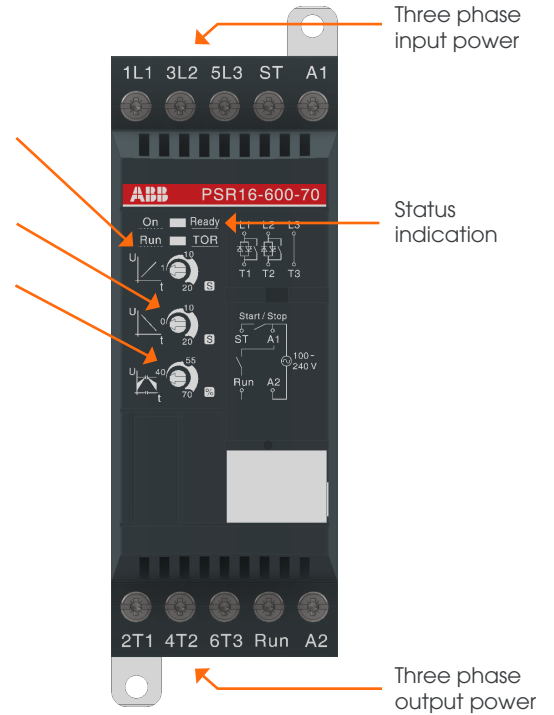

DIP SWITCH CONFIGURATION

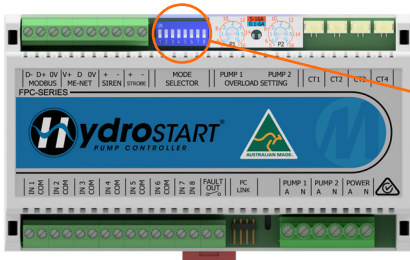

There are 8 DIP switches located on the upper side of the control module which are used to select the control mode and adjust the functions of the HydroSTART controller, as per the table below.

DIP SWITCH	POSITION	FUNCTION
1	Off	Level control mode The controller will operate in level empty control mode, controlled by up to 5 float switches. Input 1 = Low level/prime loss, Input 2 = Duty stop, Input 3 = Duty Start, Input 4 = Standby Start and Input 5 = High level.
	On	Pressure control mode The controller will operate in pressure boost control mode, controlled by up to 3 pressure switches. Input 1 = Low level/prime loss, Input 2 is unused, Input 3 = Duty start, Input 4 = Standby start and Input 5 = Low pressure.
2	Off	Prime loss protection Input 1 is configured for prime loss protection. If a pump is running and input 1 is open for 30 seconds and prime loss fault is activated for that pump, shutting it down and alternating duty. Manual reset via the mute/reset button on the keypad is required.
	On	Low level protection Input 1 is configured for low level protection. If input 1 opens for 1 second the low level fault will be activated and the pumps shut down. Manual reset via the mute/reset button on the keypad is required.
3	Off	Standard alternation mode Duty pump alternates on every start or after 30 minutes of continuous running.
	On	Recirculation alternation mode Duty pump alternates after an accumulated running time of 6 hours, irrespective of starting/stopping and the system being enabled/disabled.
4	Off	Low current range Pump current sensing is configured for low range 0.1 to 6 Amps. The overload setting dials and CT scaling will use this range. Note: This is factory default.
	On	High current range Pump current sensing is configured for high range 5 to 16 Amps. The overload setting dials and CT scaling will use this range.
5	Off	Manual mode continuous If a pump is placed in manual mode it will remain running in manual indefinitely.
	On	Manual mode timeout If a pump is placed in manual mode it will revert to auto mode after 5 minutes of running in manual.
6	Off	High level stormwater The high level alarm will activate after the high level input (input 5) is closed for 15 minutes. The alarm will automatically reset once the high level input opens.
	On	High level sewage The high level alarm will activate after the high level input is closed for 1 minute. Manual reset via the mute/reset button on the keypad is required.
7	Off	Undercurrent and zero current protection off Undercurrent and zero current protections are disabled. Use for automatic pumps or pumps with low current.
	On	Undercurrent and zero current protection on Undercurrent and zero current protections are enabled. Undercurrent - If a pump is running the current being sensed is less than 50% of the value set on the pump overload dial for 10 seconds, an undercurrent fault will be activated. Zero current - If a pump is running and the current being sensed is less than 100mA or 10% of the value set on the pump overload dial (whichever is higher) for 10 seconds, a zero current fault will be activated.
8	Off	Alternate duty Duty alternation is enabled as configured by DIP switch 3.
	On	Static duty Duty alternation or fault alternation is disabled. Pump 1 will always be the duty pump that starts first and pump 2 will always be the standby pump.

KEYPAD OPERATION

The status of the HydroSTART controller is displayed via the various indicator lights on the keypad interface. The keypad features capacitive touch buttons for muting or resetting faults, testing the keypad and alarm operation, and selecting the pump mode. The keypad connects to the HydroSTART module via a 3 wire connection (+12V, bus and ground) and communicates via the proprietary ME-NET protocol.

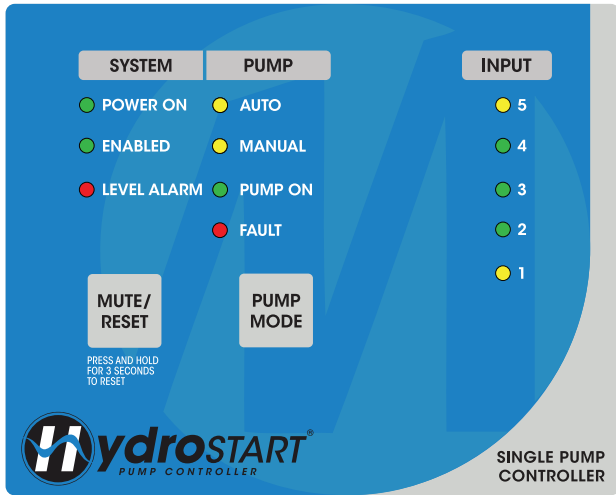

Single Pump Keypad

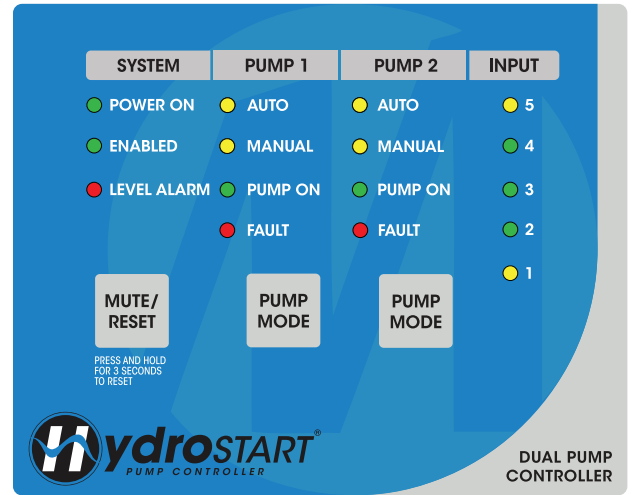

Dual Pump Keypad

The meaning of each LED status is explained below. Some LEDs have multiple functions with different flash rates corresponding with different faults or conditions. If multiple conditions are present at once, the On status will take priority, followed by 1 flash, 2 flashes and so on. For example, if there is a prime loss fault (1 flash) and an undercurrent fault (5 flashes) for pump 1, the pump 1 fault light will flash once as the prime loss fault takes precedence.

SYSTEM INDICATOR LIGHTS

- POWER ON**
Off - Power off
On - Power on
1 flash - Alarm fault
2 flash - Settings fail fault
3 flash - Contact fault
4 flash - Conductivity input fault
- ENABLED**
Off - System disabled
On - System enabled
- LEVEL ALARM**
Off - No faults active
On - High level fault
1 flash - Low level fault
2 flash - Low pressure fault

PUMP INDICATOR LIGHTS

- AUTO**
Off - Pump not in auto mode
On - Pump in auto mode
- MANUAL**
Off - Pump not in manual mode
On - Pump in manual mode
- PUMP ON**
Off - Pump not running
On - Pump running
- FAULT**
Off - Pump healthy
On - Overload fault
1 flash - Input fault
2 flash - Prime loss fault
3 flash - Max run fault
4 flash - Zero current fault
5 flash - Undercurrent fault

LEVEL INDICATOR LIGHTS

- 5**
Off - Input 1 is open
On - Input 1 is closed
- 4**
Off - Input 2 is open
On - Input 2 is closed
- 3**
Off - Input 3 is open
On - Input 3 is closed
- 2**
Off - Input 4 is open
On - Input 4 is closed
- 1**
Off - Input 5 is open
On - Input 5 is closed

Note - In tank fill mode, indicator light 4 will correspond with input 2 (duty stop), while input 2 will correspond with input 4 (standby start), so that lights reflect the position of the float switches in the tank

BUTTONS

- MUTE/RESET**
Press for 1 sec - Mutes the audible alarm
Press for 3 sec - Resets active faults, or starts the alarm test in which all indicator lights will illuminate and alarms will activate. The alarm test will stop when the button is released or after 10 seconds.
- PUMP MODE**
Press for 1 sec - Changes the pump mode from auto to manual, manual to off or off to auto.

FAULT DIAGNOSIS

FAULT TYPES

FAULT	INDICATION	RESET	TYPE
SYSTEM FAULTS			
High level fault	Level alarm = on	Automatic or Manual reset (depends on DIP switch 6)	Alarm only (no lockout)
Low level fault	Level alarm = 1 flash	Manual reset	System fault lockout
Low pressure fault	Level alarm = 2 flash	Manual reset	System fault lockout
Alarm fault	Power on = 1 flash	Automatic reset after 60 seconds	Alarm only (no lockout)
Settings fail fault	Power on = 2 flash	Manual reset	Alarm only (no lockout)
Contact fault	Power on = 3 flash	Manual reset	Alarm only (no lockout)
Conductivity input fault	Power on = 4 flash	Manual reset	Alarm only (no lockout)
PUMP FAULTS			
Overload fault	Pump fault = on	Manual reset	Pump lockout
Input fault	Pump fault = 1 flash	Manual reset	Pump lockout
Prime loss fault	Pump fault = 2 flash	Manual reset	Pump lockout
Max run fault	Pump fault = 3 flash	Manual reset	Pump lockout
Zero current fault	Pump fault = 4 flash	Manual reset	Pump lockout
Undercurrent fault	Pump fault = 5 flash	Manual reset	Pump lockout

FAULT CAUSES & REMEDIES

FAULT	CAUSE	REMEDY
SYSTEM FAULTS		
High level fault	<p>The high level input (input 5) has closed for the high level alarm delay as selected via DIP switch 6, possibly due to:</p> <ul style="list-style-type: none"> Pumps unable to keep up with inflow into the tank/pit. Fault has latched after water level has subsided following a high level event. High level float switch installed or wired incorrectly, or faulty. 	<ul style="list-style-type: none"> Check if the level in the tank/pit is at high level. If DIP switch 6 is on, the high level alarm is latching, manually reset on keypad to clear and resume operation. Check the float switch is in the correct position in tank/pit. Ensure the high level float is wired as close on rise (or close on fall if the controller is in tank fill mode). If not required, ensure the high level input is left open (or bridged if controller is in tank fill mode). Disconnect and test the float switch, replace if faulty. If a longer delay is required between the standby pump starting and high level alarm activation, consider adding a standby start float switch if not already in use.
Low level fault	<p>The low level input (input 1) has opened for 1 second, possibly due to:</p> <ul style="list-style-type: none"> Pumps have continued pumping down to low level due to faulty floats in other inputs. Fault has latched after water level has risen following a low level event. Low level float switch installed or wired incorrectly, or faulty. Incorrect DIP switch position if a flow switch is in use for prime loss protection. 	<ul style="list-style-type: none"> Check if the level in the tank/pit is at low level. Fault is latching, manually reset to clear and resume operation. Check the low level float is in the correct position in tank/pit. Ensure the low level float is wired as close on rise (typically black and brown wires are used). If not required, ensure the low level input is bridged (or left open, if controller is in tank fill mode). Disconnect and test the float switch, replace if faulty. If prime loss protection using a flow switch is required instead of low level, turn DIP switch 2 off.
Low pressure fault	<p>The low pressure input (input 5) has closed for 60 seconds, possibly due to:</p> <ul style="list-style-type: none"> Burst pipe. Loss of prime. Pumps unable to keep up with demand. Low pressure switch installed or wired incorrectly. 	<ul style="list-style-type: none"> Ensure the low pressure switch is wired into input 5 as close on low pressure. Fault is latching, manually reset to clear and resume operation. Disconnect and test the pressure switch, replace if faulty. Investigate hydraulic causes of the low pressure event.

FAULT CAUSES & REMEDIES CONT.

FAULT	CAUSE	REMEDY
Alarm fault	The combined current draw on the siren and strobe outputs has exceeded 350mA.	<ul style="list-style-type: none"> • Check strobe and buzzer connections • Ensure combined current draw on outputs does not exceed 350mA.
Settings fail fault	Settings have failed to load from EEPROM memory after a power cycle, so the default settings have been loaded.	<ul style="list-style-type: none"> • If the controller is standard with no altered settings, reset the fault and normal operation should resume. • If the controller is modified with altered settings, contact supplier for support if required.
Contact fault	Pump CTs have detected current when the pump outputs are switched off, possibly due to faulty control module or contactors	<ul style="list-style-type: none"> • If the controller is 3 phase, check that the contactors are operating correctly. • Contact supplier for support if required.
Conductivity input fault	HydroSTART module has receiving no communication from the Conductivity board, possibly due to: <ul style="list-style-type: none"> • Incorrect wiring between HydroSTART and conductivity modules. • Conductivity input enabled but Conductivity board not in use. 	<ul style="list-style-type: none"> • Check wiring between the HydroSTART module and Conductivity board. • Contact supplier for support if required.
PUMP FAULTS		
Overload fault	Pump running current has exceeded the value set on the pump overload dial resulting in an overload trip, possibly due to: <ul style="list-style-type: none"> • Pump jammed or locked. • Overload dial set incorrectly for pump FLC. • Current sensing range set incorrectly via DIP switch 4. 	<ul style="list-style-type: none"> • Check pump for jamming or locked rotor, test current draw • Ensure the pump overload dial on the control module is set correctly for the pump full load current, see 'pump current sensing' on page 11. • Ensure the pump current sensing range is set correctly to low (0.1-6A) or high (5-16A) range via DIP switch 4.
Input fault	The pump's fault input (input 7 or 8) has opened for 1 second, possibly due to: <ul style="list-style-type: none"> • Pump jammed or locked rotor. • Thermal switch has opened due to excessive motor temperature. • Thermal overload has tripped due to high current draw (if external overload in use). • Circuit breaker trip (if circuit breaker auxiliaries are used). 	<ul style="list-style-type: none"> • Check pump for jamming or locked rotor, test current draw • Check that a thermal switch, not a thermistor, is connected to the thermal switch input. • If not required, the thermal switch input must be bridged. • Check that external thermal overload is set correctly, if in use. See 'Thermal Overload Data' on page 16. • Check that the circuit breaker has not tripped, if circuit breaker auxiliary is in use.
Prime loss fault	The prime loss input (input 1) has opened for 30 seconds while a pump was running, possibly due to: <ul style="list-style-type: none"> • Stalled pump or loss of prime. • Flow switch installed or wired incorrectly, or faulty. • Incorrect DIP switch position if a low level float is in use. 	<ul style="list-style-type: none"> • Check that pump is primed. • Fault is latching, manually reset to clear and resume operation. • Check flow switch is wired into input 1 as close on flow. • Check that the flow switch is installed in correct orientation and pipe of the pump/system. • If low level protection using a float switch is required instead of prime loss, turn DIP switch 2 on.
Max run fault	Pump has been running continuously for the max run fault delay (default 30 mins), possibly due to: <ul style="list-style-type: none"> • Burst pipe. • Pump loss of prime. • No water available. • Discharge pipe blocked. 	<ul style="list-style-type: none"> • Investigate hydraulic causes of pump running continuously for the max run fault delay.
Zero current fault	Pump output is activated but CTs are detecting current below 100mA or 10% of the trip value set on the overload dial (whichever is higher), possibly due to: <ul style="list-style-type: none"> • Pump disconnected. • Pump wiring incorrect. • Pump motor open circuit. • Pump circuit breaker off. • Automatic pumps in use. 	<ul style="list-style-type: none"> • Check that the pump circuit breaker is switched on. • If pump is not being connected yet, turn pump off on keypad. • Check pump connections in the controller. • Check pump motor wiring. • If automatic pumps with their own floats are in use, tie floats in up position so that pumps will operate off the controller's floats, or disable zero/undercurrent protection by turning off DIP switch 7.

FAULT CAUSES & REMEDIES CONT.

FAULT	CAUSE	REMEDY
Undercurrent fault	<p>Pump is running and the current being sensed is below 80% of the value set on the overload dial for 10 seconds (but above 100mA or 10% of the value set on the overload dial, whichever is higher), possibly due to:</p> <ul style="list-style-type: none"> • Automatic or low current pumps in use • Pumps running dry (for centrifugal pumps) • Overload dial set incorrectly for pump FLC. • Current sensing range set incorrectly via DIP switch 4. 	<ul style="list-style-type: none"> • If automatic pumps or low current pumps are in use, it is recommended to disable zero/undercurrent protection by turning DIP switch 7 off. • Check if pumps are running dry (for centrifugal pumps). • Ensure the pump overload dial on the control module is set correctly for the pump full load current, see 'pump current sensing' on page 11. • Ensure the pump current sensing range is set correctly to low (0.1-6A) or high (5-16A) range via DIP switch 4.

OTHER COMMON ISSUES

ISSUE	POTENTIAL CAUSE	REMEDY
High level alarm not activating when high level float switch is up/closed	<ul style="list-style-type: none"> • High level input has not been closed for the high level alarm delay as selected via DIP switch 6. 	<ul style="list-style-type: none"> • Wait for the high level delay time to pass
2nd pump not stopping when standby start float switch is open	<ul style="list-style-type: none"> • In standard recirculation mode (DIP switch 3 off), after the high level input closes, the second pump will continue running until the duty start float opens. 	<ul style="list-style-type: none"> • Wait for the duty start float to open.
Low level fault not activating	<ul style="list-style-type: none"> • Prime loss protection is selected (DIP switch 1 off) instead of low level for input 1. 	<ul style="list-style-type: none"> • Turn DIP switch 1 on for low level protection.
Pumps not running in auto mode when floats switches are closed	<ul style="list-style-type: none"> • System is disabled, preventing the pumps from running in auto mode. 	<ul style="list-style-type: none"> • If the system enable input is not in use, ensure it is bridged.
No indicator lights on keypad	<ul style="list-style-type: none"> • Loss of power supply to the controller. • Keypad cable damaged or disconnected. 	<ul style="list-style-type: none"> • Ensure the main isolator is on or check power supply to the controller. • Check cable between keypad and control module.

MAINTENANCE

Below is a recommended maintenance routine for the controller. How regularly it should be performed is dependent on the environment the controller is located in. Maintenance will need to be performed more regularly on controllers that are installed in more extreme environments, including those subject to corrosion, dust and vibration.

- Tighten screws, as these may have loosed over time, due to temperature changes
- Inspect all cables for damage
- Test correct operation of the keypad interface
- Check that the alarm strobe and buzzer are operating correctly, if applicable
- Manually start and stop the pumps to ensure the controller is operating correctly
- Clean out the enclosure fan and vents, if applicable
- Wipe down the enclosure, remove any build up of material on the exterior and interior
- Check integrity of enclosure for rusting and moisture ingress, ensure the door seal is sealing the enclosure correctly
- Conduct a thermography test to detect hot spots in the panel

OPTIONAL FUNCTIONALITY

TANK FILL CONTROL MODE

The HydroSTART has the ability to operate in tank fill control mode, where operation is reversed from the standard level empty mode. This function cannot be configured by the user and must be requested on ordering. DIP switch 1 must be off so the controller operates in level mode. Float switches are wired into the inputs as close on fall, starting the pumps as the level drops. The level indicator lights on the keypad illuminate when the inputs are open/float switches are up. The order of inputs is changed so that the level indicator lights corresponds with the position of the float switches in the tank. Input 4 is now used for duty stop and input 2 for standby start.

Operation in tank fill mode will be as follows. As the water level in the tank/pit falls and the duty start input closes, the duty pump will start, and will continue running until both the duty start and duty stop inputs open. If the water level continues falling and the standby start input closes, the standby pump will start to assist the duty pump and will stop when the standby start input opens.

If the low level input closes, both pumps will start if not already running, and a low level alarm will activate after a 1 second delay. The low level alarm will remain active until manually reset by pressing the mute/reset button on the keypad for 3 seconds. Note this low level functionality will only operate if input 1 is configured for low level, with DIP switch 1 on.

If the high level input opens for the high level alarm delay, as selected by DIP switch 6, the high level alarm will be activated and the pumps shut down. The pumps will be allowed to run again once the high level input closes. The high level alarm will either automatically reset or remain active until manual reset, as selected by DIP switch 6.

If a low level alarm is active, running both pumps, then the high level and one other input opens, high level will override low and the pumps will stop. If a high level alarm is active, stopping the pumps from running, then the low level and one other input closes, low level will override high and both pumps will run. These overrides prevent overflowing or dry running in case of faulty floats.

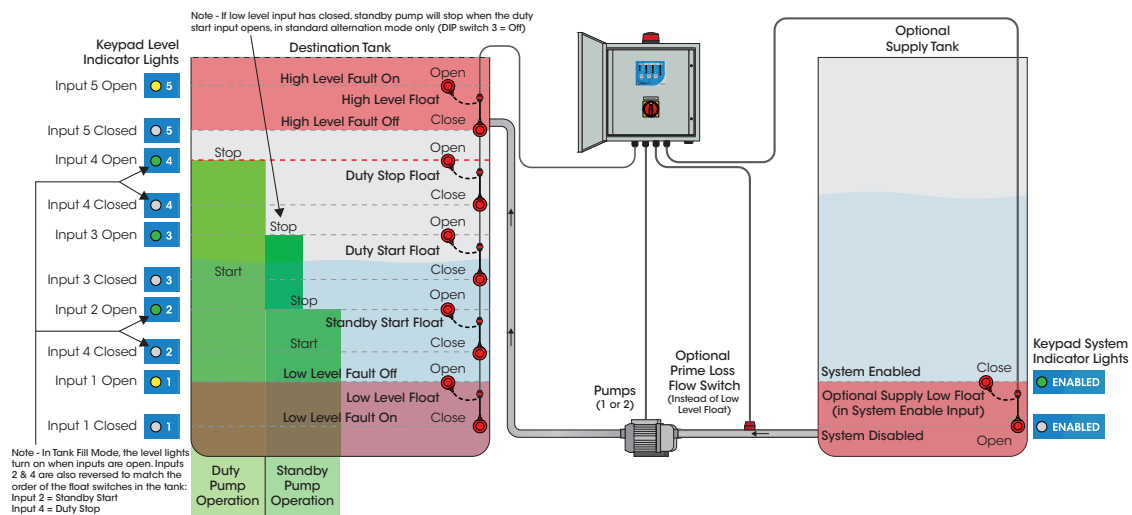

Tank Fill Control Connections - Single Pump

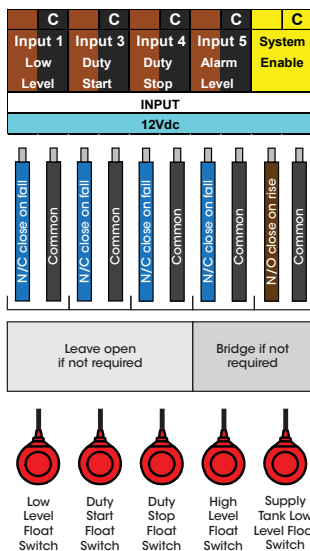

Tank Fill Control Connections - Dual Pump

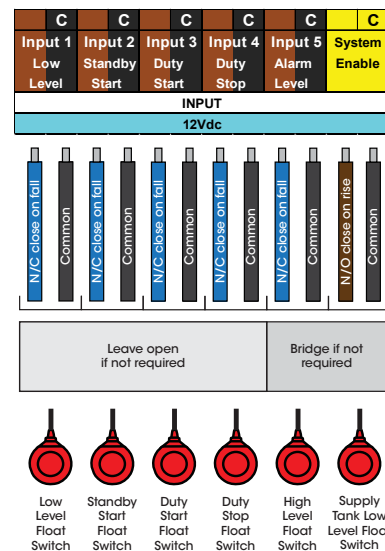

MAX RUN PROTECTION

The maximum run fault is used in applications where in the event a pump runs for too long, a fault must be triggered and the pump shut down, with duty alternating to the other pump. This function is not enabled as default and must be requested on ordering. The maximum run protection will operate in both auto and manual pump modes. If a pump runs continuously for the max run fault delay (default 30 minutes), a max run fault will be triggered, and the pump shut down. A max run fault is indicated by the corresponding pump fault light on the keypad flashing three times. The fault will remain active until manually reset by pressing the mute/reset button on the keypad for 3 seconds.

PUMP LIMITING

In certain applications it is not desirable to allow both pumps to run together, possibly due to insufficient power supply or pipe capacity. To accommodate this, pump limiting can be enabled to limit the controller to run one pump at a time. This function cannot be enabled by the user and must be requested on ordering. In level control mode, if the high level input (or low level in tank fill mode) closes, instead of starting both pumps, the controller will alternate duty to the other pump in case an issue with the first pump was preventing it from pumping enough water. Similarly, in pressure control mode, if the low pressure input closes, duty will alternate. Pump limiting will be overridden if pumps are placed in manual mode on the keypad.

SERVICE ALARM

The service alarm can be enabled to remind the user that the pump system is due to be serviced. This function cannot be enabled by the user and must be requested when ordering. The standard HydroSTART keypad does not include the service alarm indicator light. If enabled, the service alarm will activate after 547 days (18 months). The service alarm can be reset by turning off power to the panel, then turning power back on and pressing the mute/reset button within the first 10 seconds of the controller being powered up.

HydroSTART BMS VARIATION

The BMS variation of the HydroSTART features the HydroSTART BMS module, providing volt free outputs for power on, high and low level, individual pump run and fault as standard, in addition to the common fault output included on other variations.

BMS MODULE

The HydroSTART BMS module features 7 volt free relay outputs providing status information to BMS systems from a HydroSTART control module. Similarly to the HydroSTART keypad, the BMS module connects to the HydroSTART control module via a 3 wire connection (+12V, bus and ground) and communicates via the proprietary ME-NET protocol. The BMS module also includes a power/status LED to indicate power and communication status. The default functions that these relays are assigned to is shown below:

- Relay 1 = Power On
- Relay 2 = Low Level
- Relay 3 = High Level
- Relay 4 = Pump 1 Run
- Relay 5 = Pump 2 Run
- Relay 6 = Pump 1 Fault
- Relay 7 = Pump 2 Fault

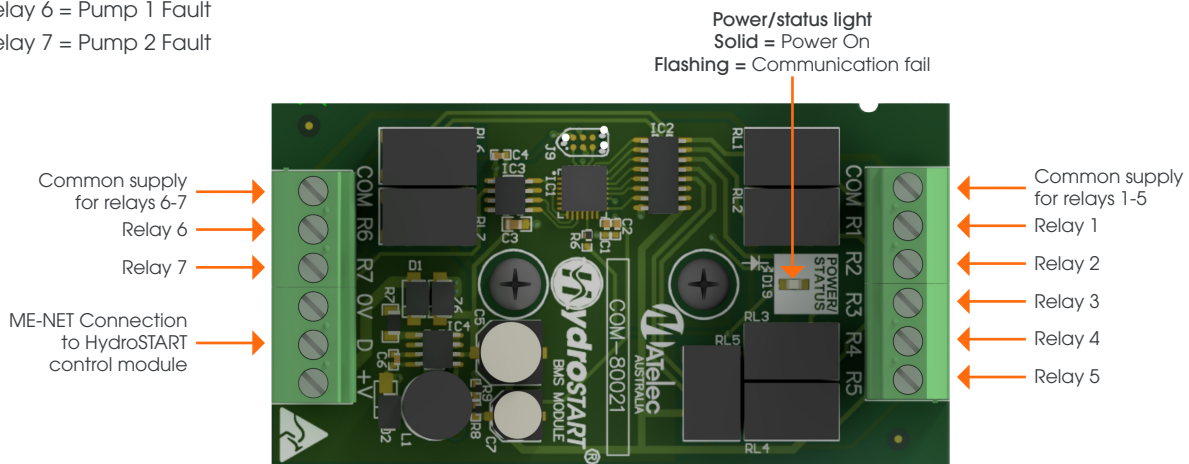

Volt Free Connections - Single Pump

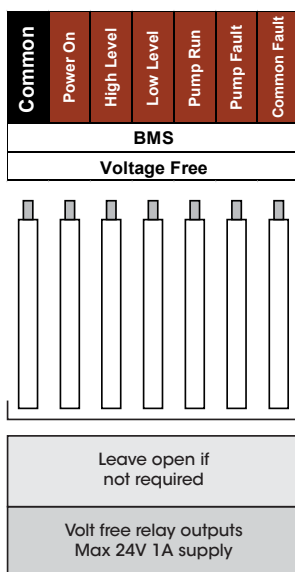

Volt Free Connections - Dual Pump

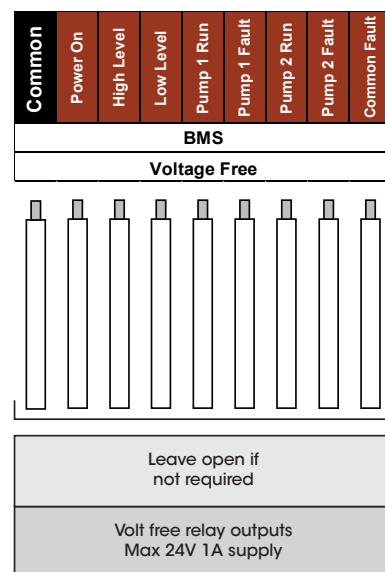

HydroSTART RMC/PL VARIATION

The HydroSTART with Rain/Mains Changeover is designed for pressure pumping applications that require mains bypass, featuring an output for a pulse latching 12VDC solenoid valve to maintain water supply when the pumping system is off or locked out due to a fault, the supply tank is low or on power failure.

VALVE INSTALLATION



- Valve needs to be selected for correct hydraulic and electrical operations.
- Valve must be installed in accordance with appropriate Plumbing Industry 'Code of Practice'.
- Valve must be installed on discharge side of the pump, not on the suction side.
- Ensure the direction of flow shown on the valve is adhered to when installing the valve.
- For best performance, the valve should be mounted in a horizontal position with the solenoid upright.
- If the valve has a manual override lever, ensure it is in the off/closed or auto position.
- If the valve has a flow control handle, screw it down until just tight, then back off two full turns to start with. This can then be adjusted further depending on the system pressure.
- The valve requires a certain amount of head pressure (varies depending on valve size) to operate correctly.
- Check the valve specifications and ensure that the pressure and flow ranges are within the limits.
- Ensure that no foreign materials enter the valve during installation to ensure the valve operates correctly.

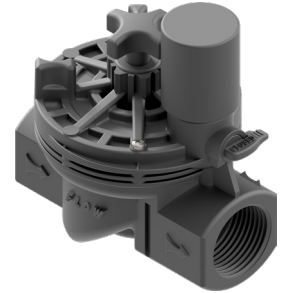

RAIN/MAINS CONNECTIONS



Single Pump

C	C	C	+	-
Low Level Float	Input 2 Duty Start	Input 5 Low Pressure	Mains Bypass Valve	
INPUT				Solenoid
12Vdc				

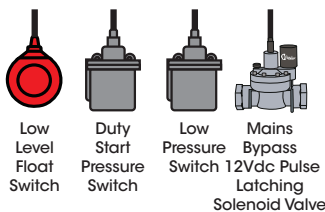
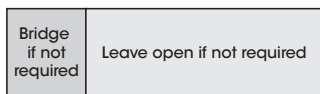
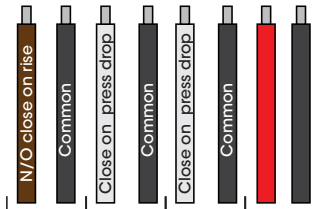

Dual Pump

C	C	C	C	+	-
Low Level Float	Input 2 Duty Start	Input 3 Standby Start	Input 5 Low Pressure	Mains Bypass Valve	
INPUT				Solenoid	
12Vdc					

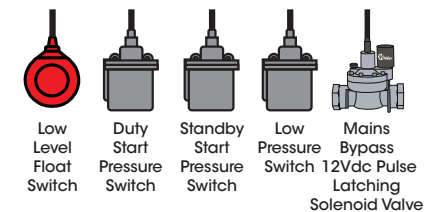
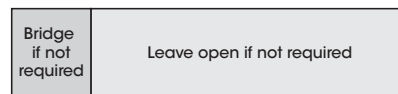
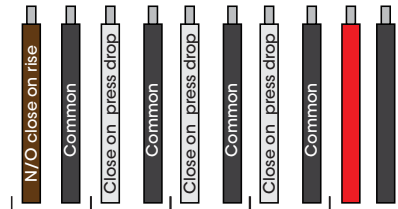

Note - Not all pressure switches are required for operation, for example a single pressure switch could be connected to the duty start input if only one pump is required to run at one time. The low level float is required for rain/mains switchover.

KEYPAD INDICATION

The system enabled indicator light on the HydroSTART keypad indicates whether rain or mains water is in use. If the HydroSTART is enabled, the pumps supply water from the tank and the valve will be closed. If the HydroSTART is disabled, the level in the tank is low and the pumps will not operate, and the valve will be open for mains water use.



Off - System disabled - Mains water in use
On - System enabled - Rain water in use

RAIN/MAINS CONTROL MODULE CONNECTIONS

The RMC/PL variation of the HydroSTART features the rain/mains control module, providing the output for the pulse latching solenoid valve. The module gives two consecutive pulses to ensure the valve opens or closes, with a short delay in between to charge the capacitor. When power to the panel is turned off or fails, power stored in the onboard capacitors sends a single pulse to open the valve. The low level float and common fault output from the HydroSTART module is connected to the main/rains module inputs to control the valve. The auxiliary output on the rain/mains module is connected to the HydroSTART system enable input to enable and disable the pumps. If the controller or pumps goes into fault, the valve output with pulse to open the valve and disable the pumps.

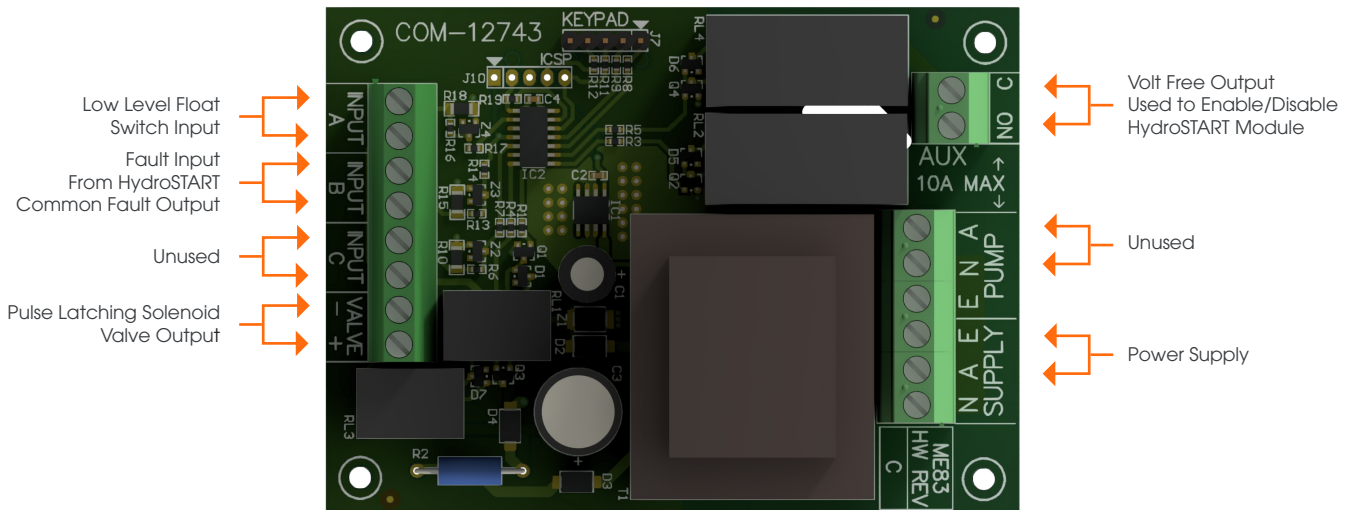

VALVE FAULT DIAGNOSIS

If the pulse latching solenoid valve is not opening or closing, firstly ensure that the valve is installed according to 'Valve Installation' on the previous page. Check that the specifications of the valve suits the installation and ensure that the solenoid is wired into the controller in the correct polarity.

Firstly, ensure that the system is in rain water state with the valve closed, not in mains water state with the valve open due to low water level or a fault. Then perform the following steps:

Solenoid and rain/mains module test:

- Isolate water supply to the valve.
- Turn off power to the panel.
- Carefully unscrew the solenoid from the valve.
- Ensure the spring is inserted into the plunger correctly and push the plunger in flush with the top of the solenoid.
- With a thumb hovered over the plunger, turn on power to the panel and see if the plunger pops out of the solenoid.
- Wait at least 10 seconds then remove power to the panel and see if the plunger sucks in flush with the top of the solenoid.
- If the plunger does not move successfully to both of these positions, the solenoid or rain/mains control module is faulty and should be replaced.
- If the plunger moves successfully, however, continue through the below steps.

Valve test:

- Clean any dirt or grit out of the hole that the solenoid screws into.
- Re-insert the solenoid with the plunger pushed in flush and open the water supply to the valve.
- Adjust the flow control handle in or out until you can hear water flowing through the valve.
- Once water is flowing, turn on power to the panel. Check that the water stops flowing through the valve.
- If not, adjust the valve open or closed until the water stops flowing and retest the valve opening by turning off power to the panel.
- If the valve still fails to open or close without adjustment, check the pressure and flow ranges suits the valve used. If so, only the valve needs replacing.

HydroSTART RMC/AC VARIATION

The HydroSTART with Rain/Mains Changeover is designed for pressure pumping applications that require mains bypass, featuring an output for a 24Vac normally open solenoid valve to maintain water supply when the pumping system is off or locked out due to a fault, the supply tank is low or on power failure.

VALVE INSTALLATION



- Valve needs to be selected for correct hydraulic and electrical operations.
- Valve must be installed in accordance with appropriate Plumbing Industry 'Code of Practice'.
- Valve must be installed on discharge side of the pump, not on the suction side.
- Ensure the direction of flow shown on the valve is adhered to when installing the valve.
- For best performance, the valve should be mounted in a horizontal position with the solenoid upright.
- If the valve has a manual override lever, ensure it is in the off/closed or auto position.
- If the valve has a flow control handle, screw it down until just tight, then back off two full turns to start with. This can then be adjusted further depending on the system pressure.
- The valve requires a certain amount of head pressure (varies depending on valve size) to operate correctly.
- Check the valve specifications and ensure that the pressure and flow ranges are within the limits.
- Ensure that no foreign materials enter the valve during installation to ensure the valve operates correctly.

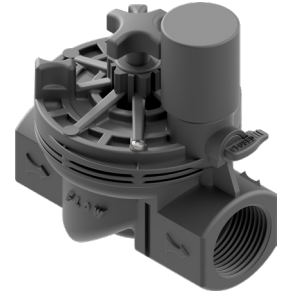

RAIN/MAINS CONNECTIONS



Single Pump

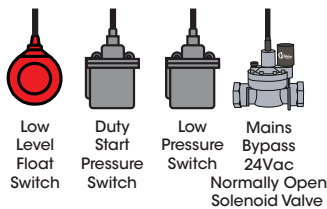
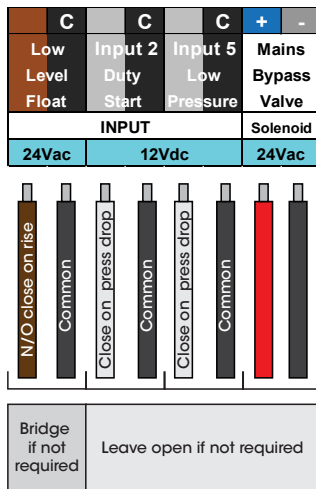

Dual Pump

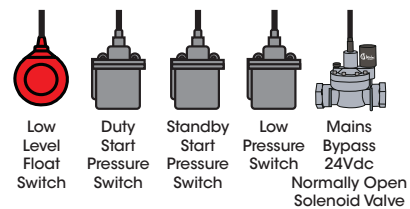
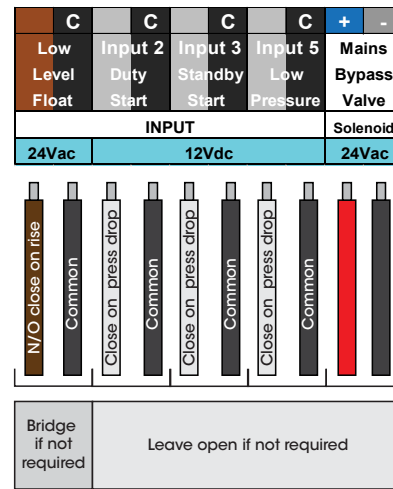

Note - Not all pressure switches are required for operation, for example a single pressure switch could be connected to the duty start input if only one pump is required to run at one time. The low level float is required for rain/mains switchover.

KEYPAD INDICATION

The system enabled indicator light on the HydroSTART keypad indicates whether rain or mains water is in use. If the HydroSTART is enabled, the pumps supply water from the tank and the valve will be closed. If the HydroSTART is disabled, the level in the tank is low and the pumps will not operate, and the valve will be open for mains water use.



Off - System disabled - Mains water in use
On - System enabled - Rain water in use

RAIN/MAINS CONTROL MODULE CONNECTIONS

The RMC/AC variation of the HydroSTART features a rain/mains control function, providing the output for the 24Vac normally open solenoid valve. When power to the panel is turned off or fails, power is removed to the valve allowing it to open. The low level float and common fault output from the HydroSTART module is connected to the main/rains inputs to control the valve. The rain/mains function is connected to the HydroSTART system enable input to enable and disable the pumps. If the controller or pumps goes into fault, the valve output power is removed to open the valve and disable the pumps.

VALVE FAULT DIAGNOSIS

If the 24Vac solenoid valve is not opening or closing, firstly ensure that the valve is installed according to 'Valve Installation' on the previous page. Check that the specifications of the valve suits the installation and ensure that the solenoid is wired into the controller in the correct polarity.

Firstly, ensure that the system is in rain water state with the valve closed, not in mains water state with the valve open due to low water level or a fault. Then perform the following steps:

Solenoid and rain/mains module test:

- Isolate water supply to the valve.
- Turn off power to the panel.
- Carefully unscrew the solenoid from the valve.
- Ensure the spring is inserted into the plunger correctly and push the plunger in flush with the top of the solenoid.
- With a thumb hovered over the plunger, turn on power to the panel and see if the plunger pops out of the solenoid.
- Wait at least 10 seconds then remove power to the panel and see if the plunger sucks in flush with the top of the solenoid.
- If the plunger does not move successfully to both of these positions, the solenoid or rain/mains control module is faulty and should be replaced.
- If the plunger moves successfully, however, continue through the below steps.

Valve test:

- Clean any dirt or grit out of the hole that the solenoid screws into.
- Re-insert the solenoid with the plunger pushed in flush and open the water supply to the valve.
- Adjust the flow control handle in or out until you can hear water flowing through the valve.
- Once water is flowing, turn on power to the panel. Check that the water stops flowing through the valve.
- If not, adjust the valve open or closed until the water stops flowing and retest the valve opening by turning off power to the panel.
- If the valve still fails to open or close without adjustment, check the pressure and flow ranges suits the valve used. If so, only the valve needs replacing.

CONDUCTIVITY MODULE

The CON variation of the HydroSTART controller features a Conductivity Module, providing Low Voltage Inputs for a Low Level, Duty Stop, Standby Start (Dual Pump Only) and High Level Conductivity Probe Inputs. The Conductivity Module also allows the user to program a time delay between signal received from a probe and signal sent to the controller.

CONDUCTIVITY MODULE

The HydroSTART Conductivity module features 6 Low Voltage inputs for Conductivity Probes providing control signals to the HydroSTART control module. Similar to the HydroSTART keypad, the Conductivity module connects to the HydroSTART control module via a 3 wire connection (+12V, bus and ground) and communicates via the proprietary ME-NET protocol. The Conductivity module also includes an adjustable time delay to programme a delay between probe signal received and signal sent to PCB assisting in alleviating false alarms. The default functions of each input probe are shown below:

- COM - Common
- CH1 - Low Level Probe
- CH2 - Duty Stop Probe
- CH3 - Duty Start Probe
- CH4 - Standby Start Probe (Only Applicable in Single Pump Configurations)
- CH5 - High Level Probe

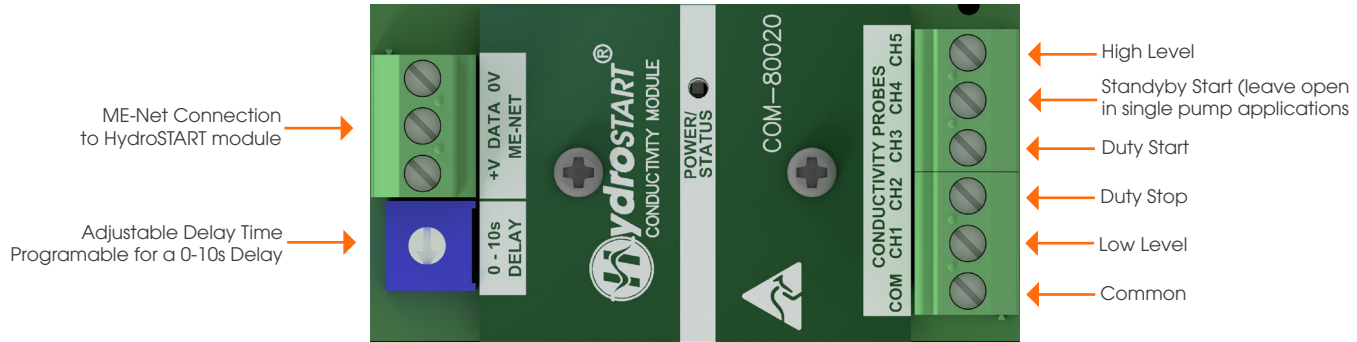

Conductivity Connections - Single

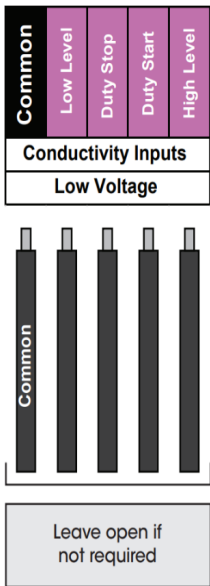

Conductivity Connections - Dual Pump

